

S I M O N E K O E N

INTERIOR DESIGN PORTFOLIO 2021 & 2022



CONTACT INFO

✉ simonekoenie@gmail.com

☎ 076 301 8984

📍 Cape Town, South Africa

C O N T E N T S

1. THE URBAN
EXPERIENCE
PAGE : 2-11

2. KSA | KITCHEN
DESIGN
PAGE : 12-16

3. PG BISON |
16XONEIGHT
PAGE : 17-20

4. TREEHOUSE |
WHITE BOX
PAGE : 21-24

5. DOCK HAUS |
HOTEL LOBBY
PAGE : 25-29

6. RESIDENTIAL DESIGN
| TRILL ROAD
PAGE : 30-32

7. WORKING DRAWING
PACKAGE
PAGE : 33-39

01.
U R B A N
E X P E R I E N C E
H O L D I N G H O T E L & P O D

ESCAPING THE CITY LIFE. WHILE WAITING TO ESCAPE YOU WILL BE SLEEPING AT ZENITH THE HOLDING HOTEL. MATROOSBERG IS 3 HOURS AWAY, THE PERFECT DISTANCE FROM THE BUSY CITY. KEEPING EVERYTHING CALM AND SIMPLISTIC YET LUXURIOUS. IT IS A PLACE THAT SEAMLESSLY OFFERS LUXURY AND COMFORT. TAKE A PERFECT DIP IN THE WARM BATH WHILE ENJOYING THE FRIGID SCENEIC VIEW OF THE OUTSIDE. ZENITH , THE PEAK OF.. THE PEAK OF ADVENTURE.



RECEPTION VIEW



WAITING AREA





SLOW LOUNGE & BAR AREA

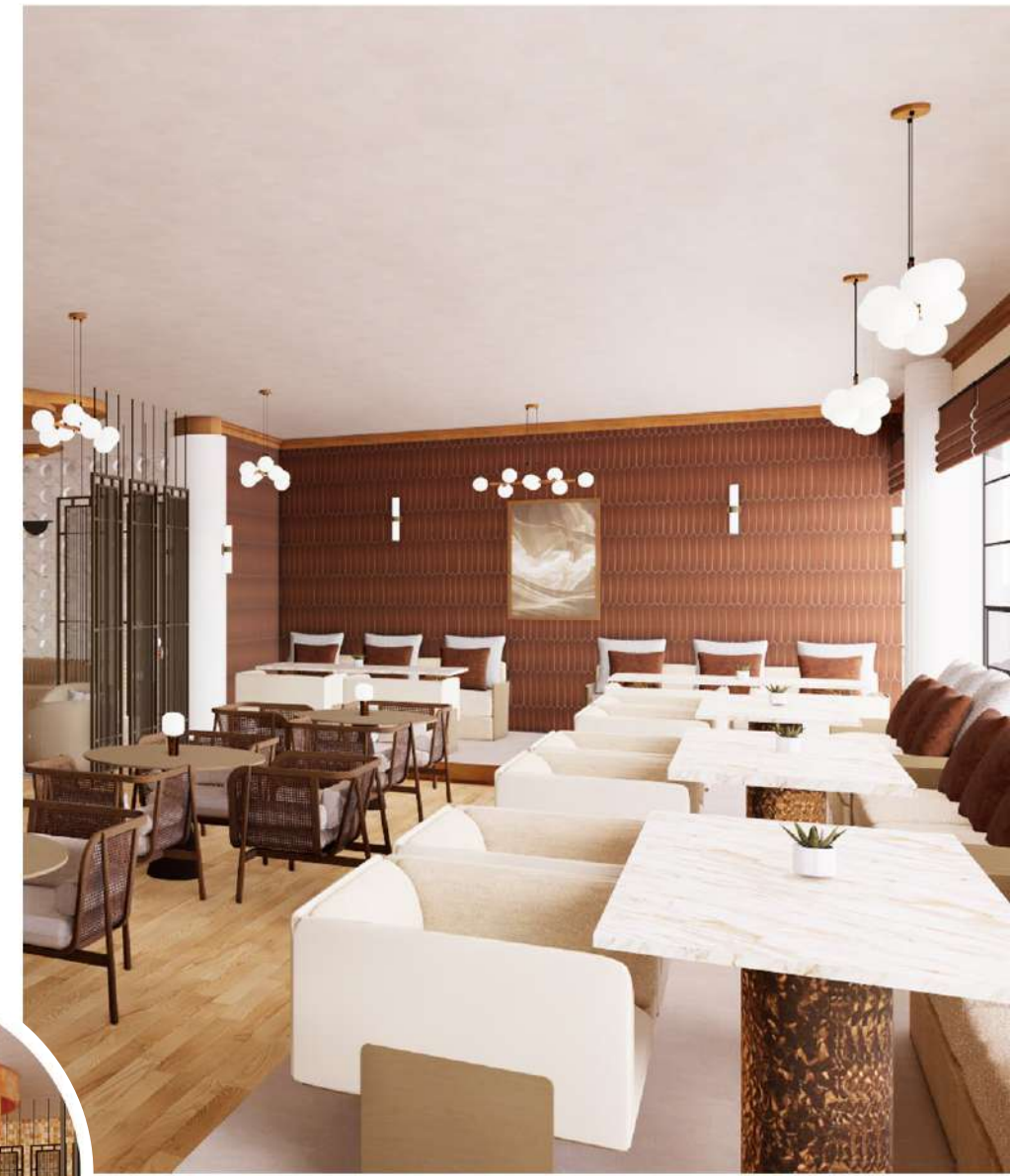

RESTAURANT VIEW



FLOORPLAN & AXO

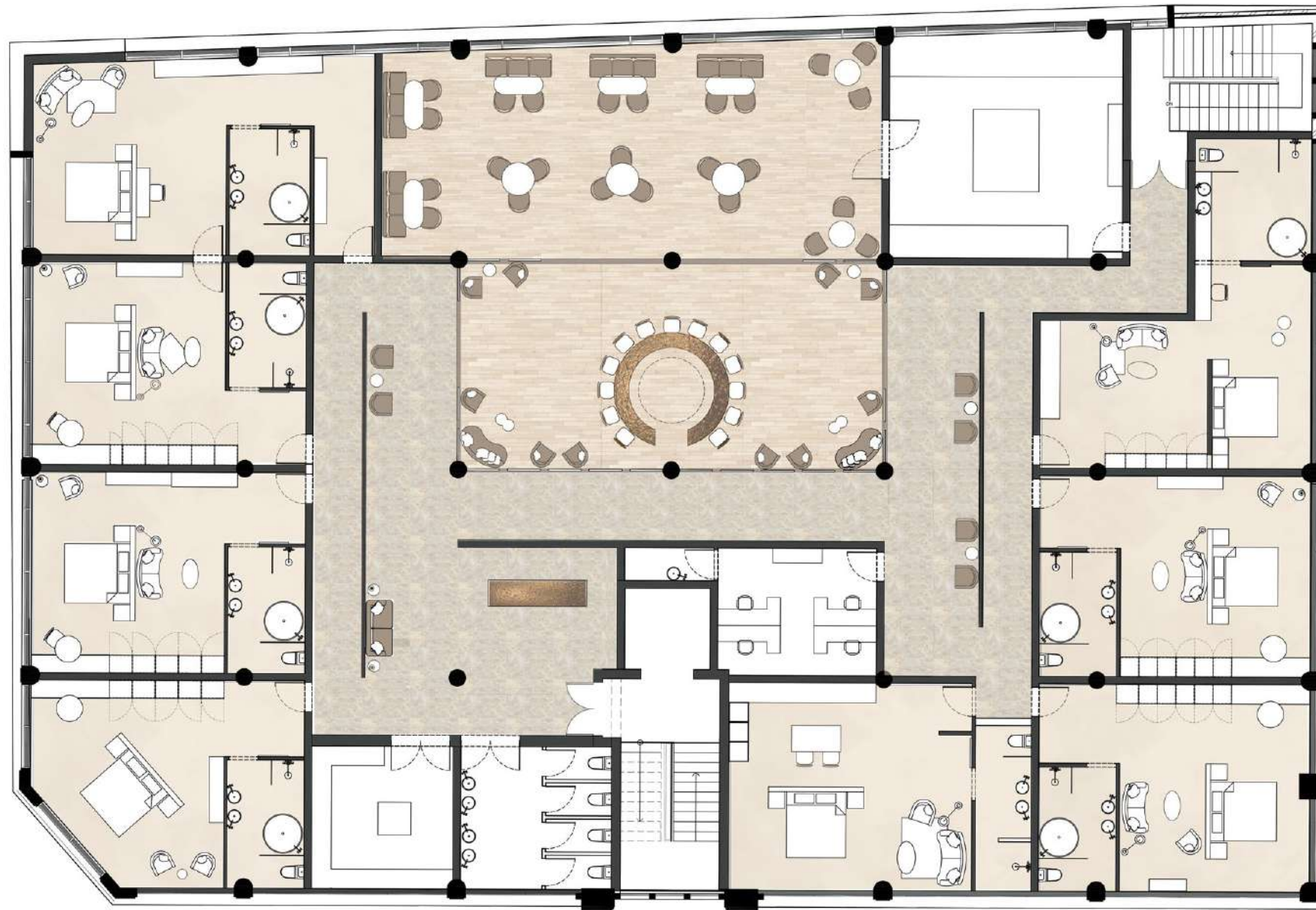

HOTEL FLOORPLAN NTS



AXO OF BEDROOM



BATHROOM IN BEDROOM



LOUNGE SEATING IN BEDROOM



URBAN EXPERIENCE | BAR PLAN

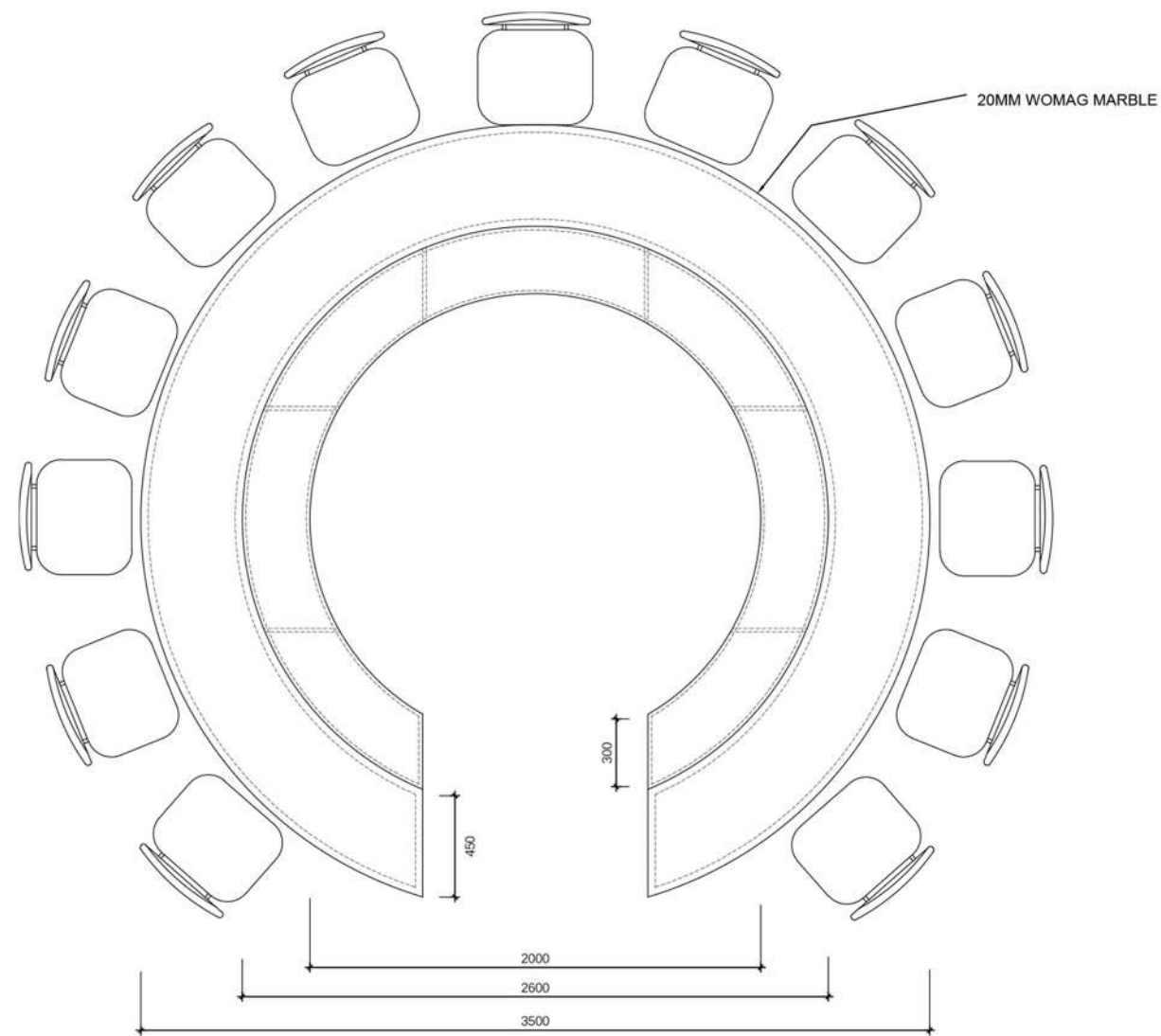

BAR WITH CUPBOARDS DASHED PLAN NTS

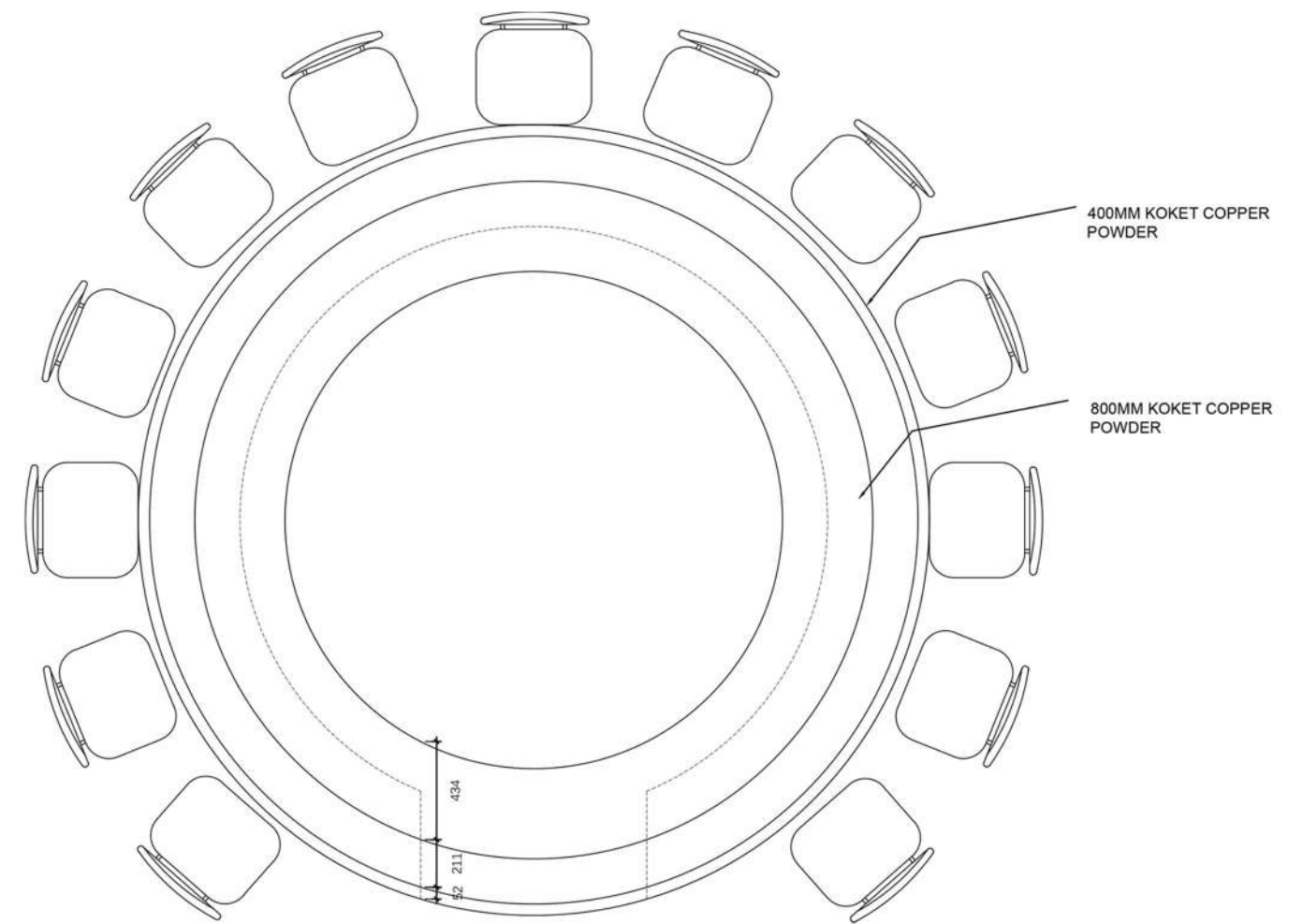

ABOVE BAR PLAN NTS

URBAN EXPERIENCE | BAR ELEVATION

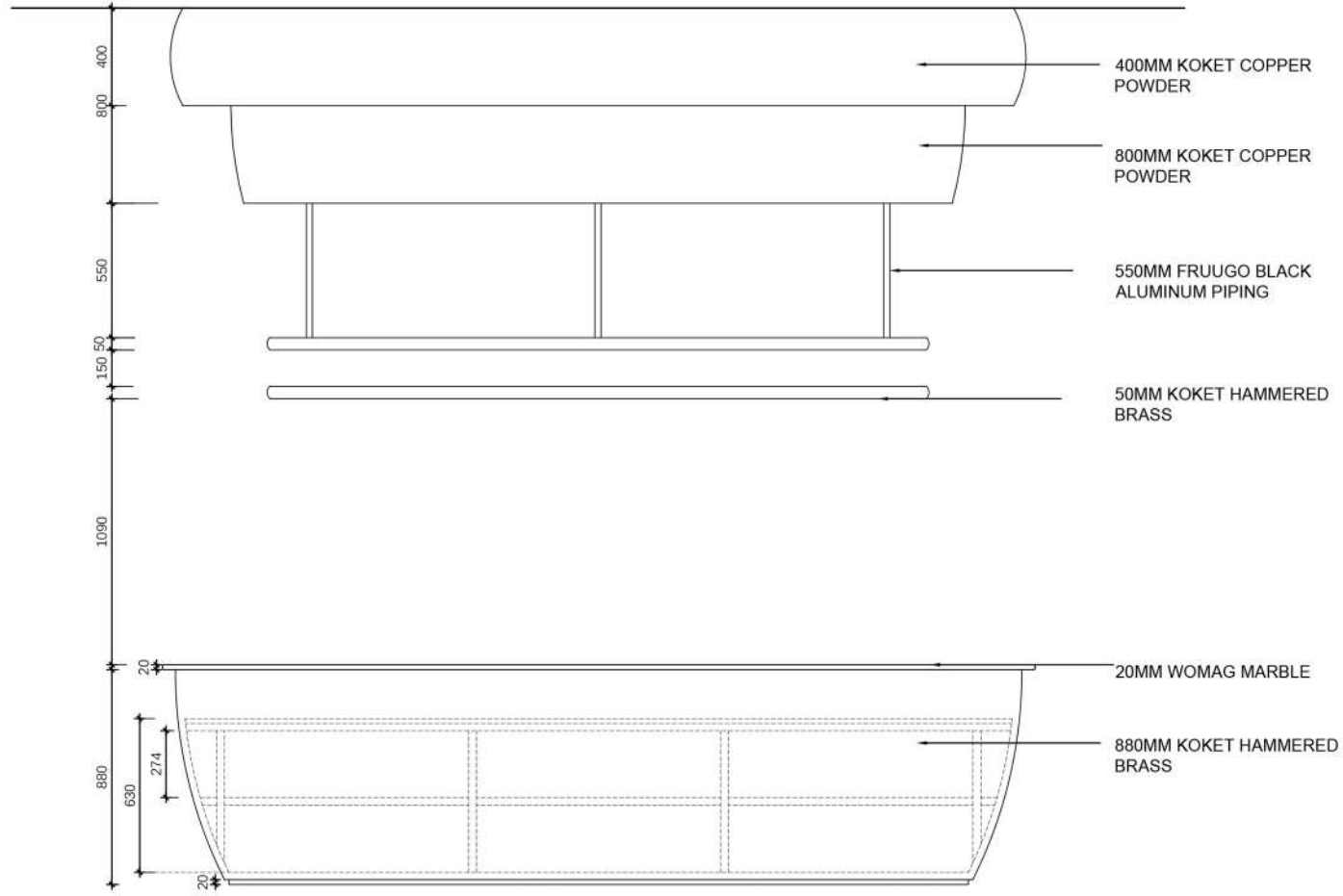

FRONT VIEW ELEVATION NTS

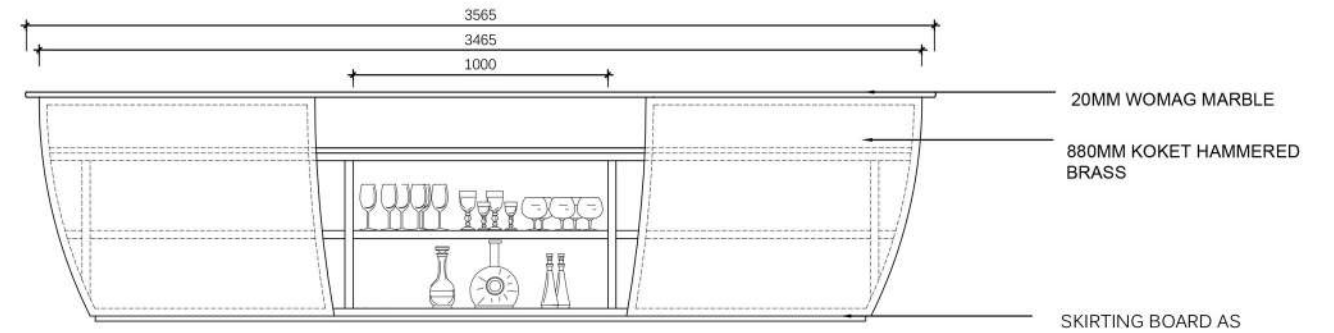
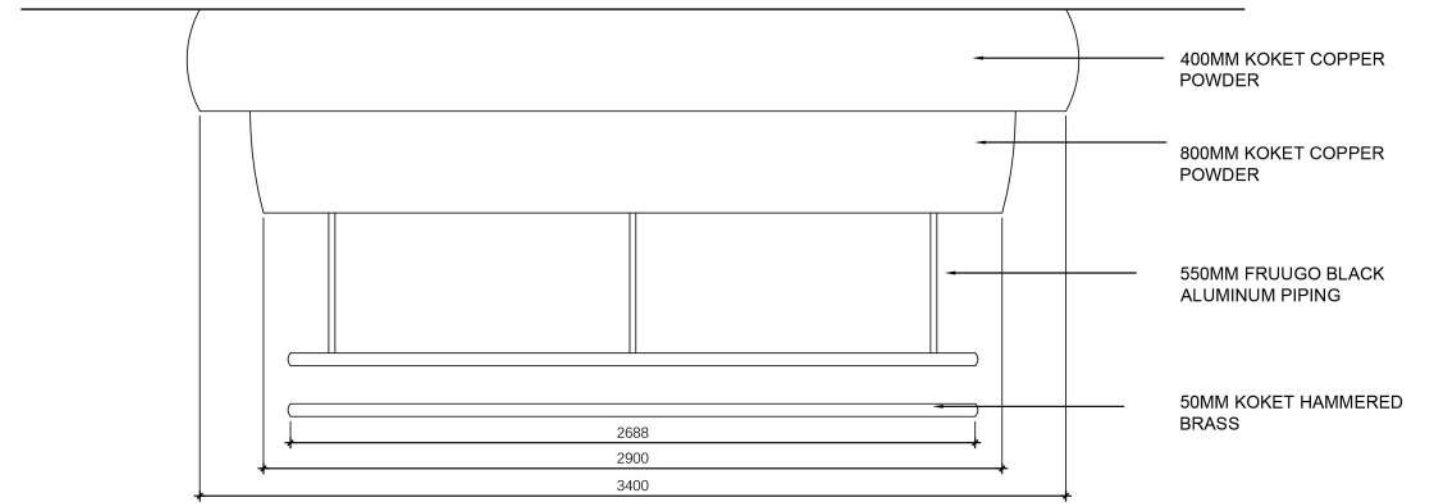

BACK VIEW ELEVATION NTS

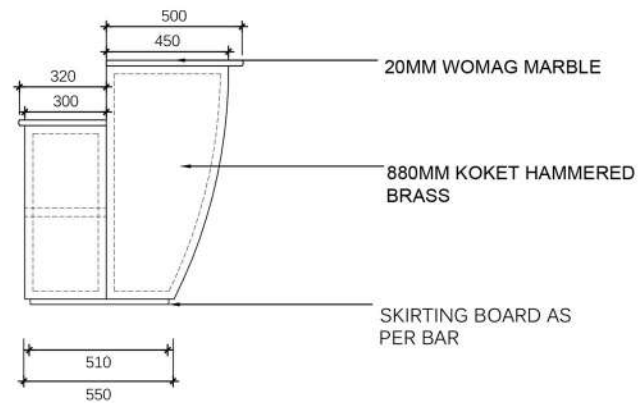

SIDE & DETAIL ELEVATION NTS



VIEW OF POD FROM
OUTSIDE



MAIN BEDROOM



LIVING AREA



SECOND BEDROOM



POD BEDROOM



LIVING ROOM



DINING AREA



POD KITCHEN



S I T E & F L O O R P L A N

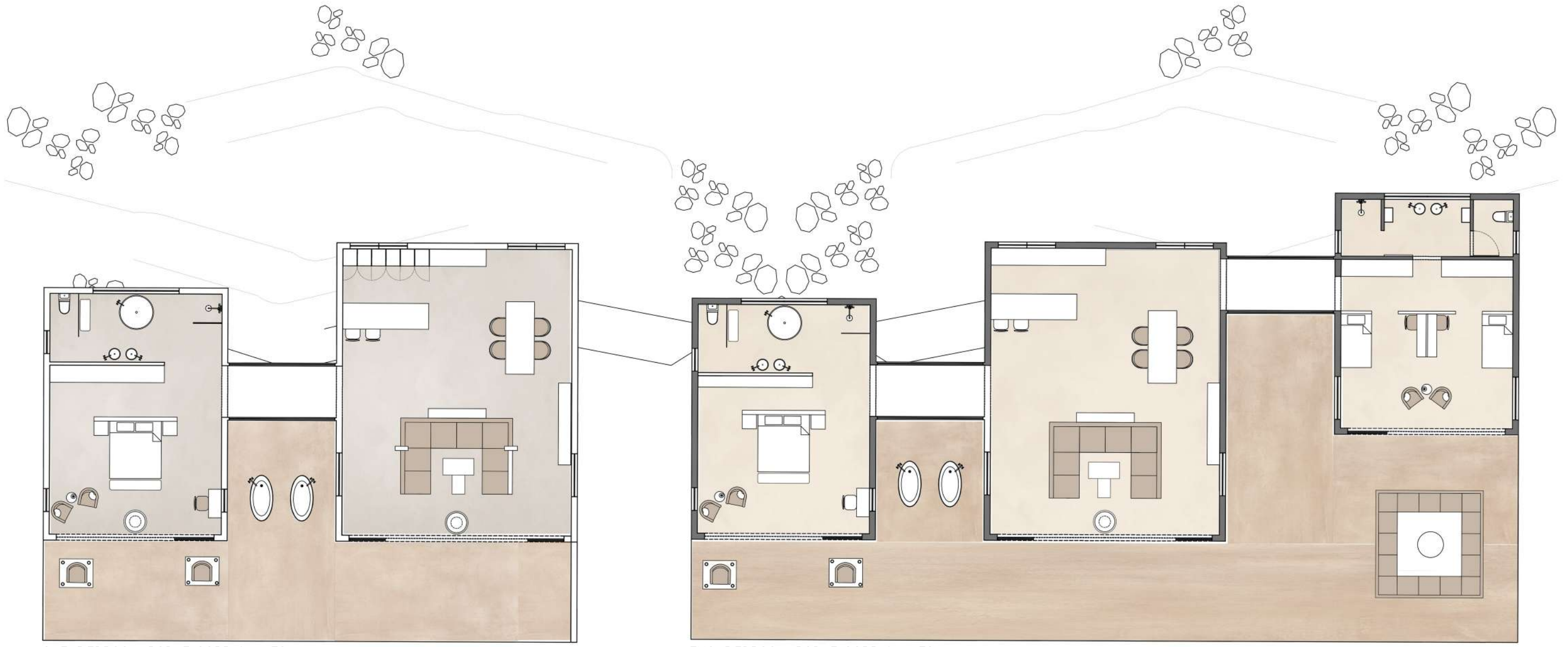

ONE BEDROOM POD FLOORPLAN NTS

TWO BEDROOM POD FLOORPLAN NTS

02.

K S A

K I T C H E N D E S I G N

THE CLIENTS I HAVE CHOSEN IS THE FIRST OPTION. THE CLIENTS ARE A MATURE ELDERLY COUPLE. THE COUPLE HAS REQUESTED FOR A CONTEMPORAY LOOK. I WILL BE FOLLOWING THE LOOK AND FEEL OF A VICTORIAN STYLE WITH BRASS ACCENTS. I HAVE ALSO DESIGNED A CUSTOMIZED KITCHEN ISLAND TO SUIT THEIR NEEDS FOR EXTRA COUNTER SPACE.

THE FEEL OF THE KITCHEN IS SOPHISTICATED.

THERE ARE SEPERATE ROOMS FOR THE SCULLERY AND A SEPERATE WASH AREA. I ADDED A DOOR TO SEPEARTE THE KITCHEN FROM THOSE AREAS WHICH MAKES IT FEEL HIDDEN AWAY FOR WHEN THE COUPLE IS ENTERTAINING FRIENDS AND FAMILY.



OVERVIEW OF KITCHEN



PG BISSON - AZZANO



CUT AT OGGIE



STILES TILES - GLOBAL MOSAIC STONE



OGGIE - NIGHT SHADE



OGGIE - PURE COLOR WHITE



OGGIE - PURO GREY



KITCHEN VIEW



SCULLERY



KITCHEN VIEW



WASH UP AREA

K S A | K I T C H E N F L O O R P L A N

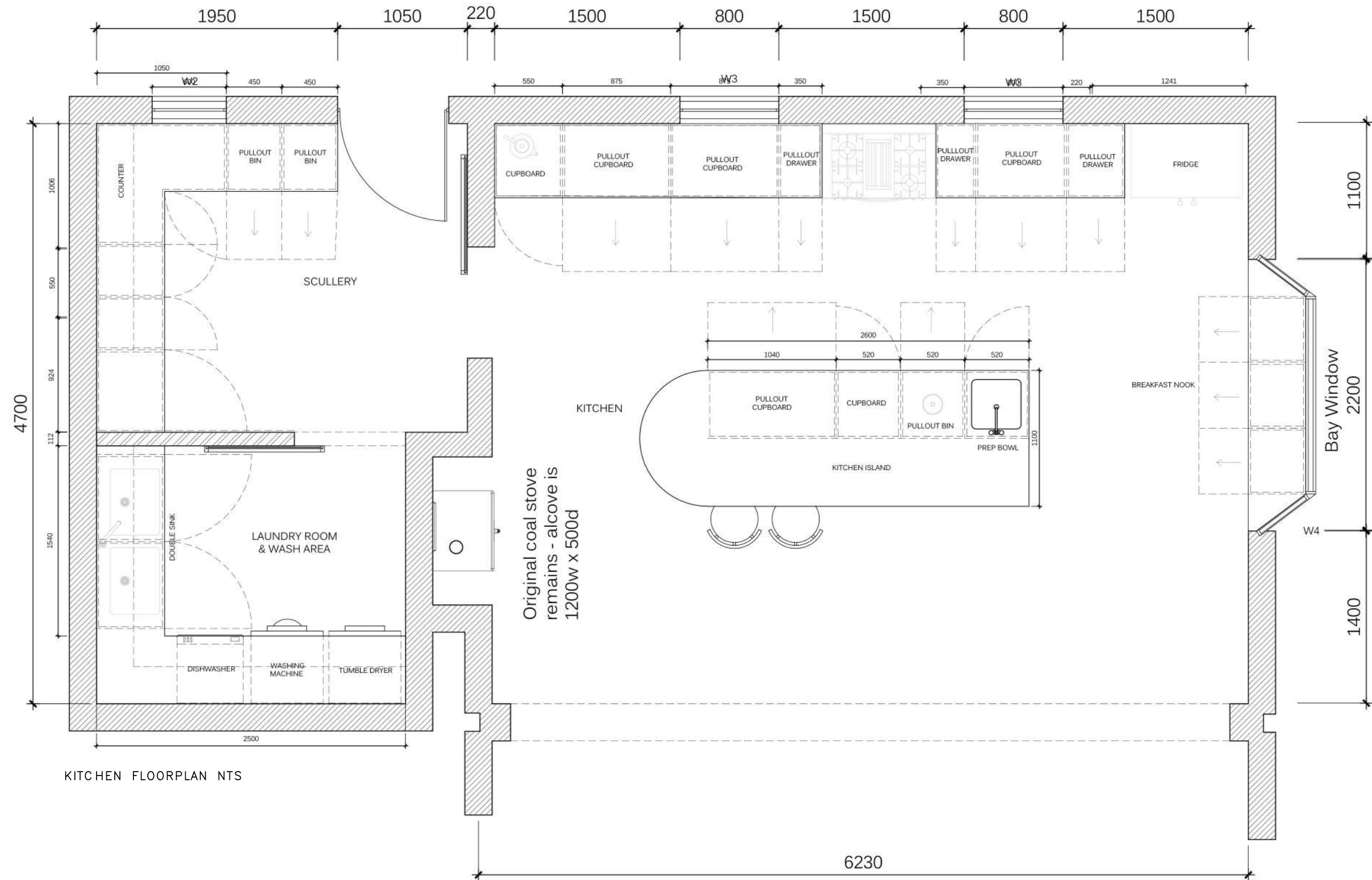

KITCHEN FLOORPLAN NTS

K S A | K I T C H E N E L E V A T I O N S

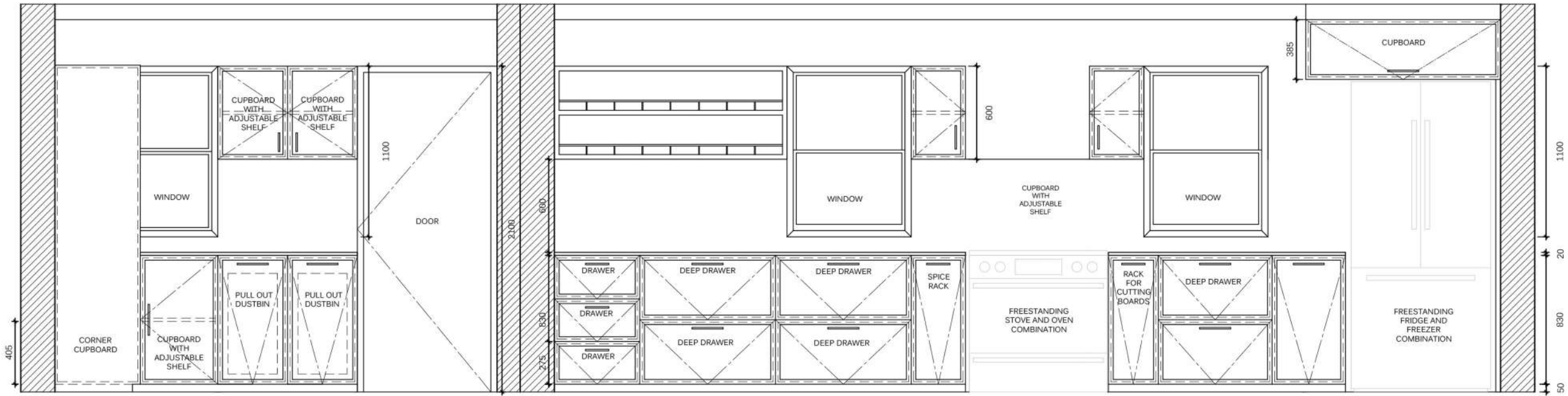

KITCHEN A ELEVATION NTS

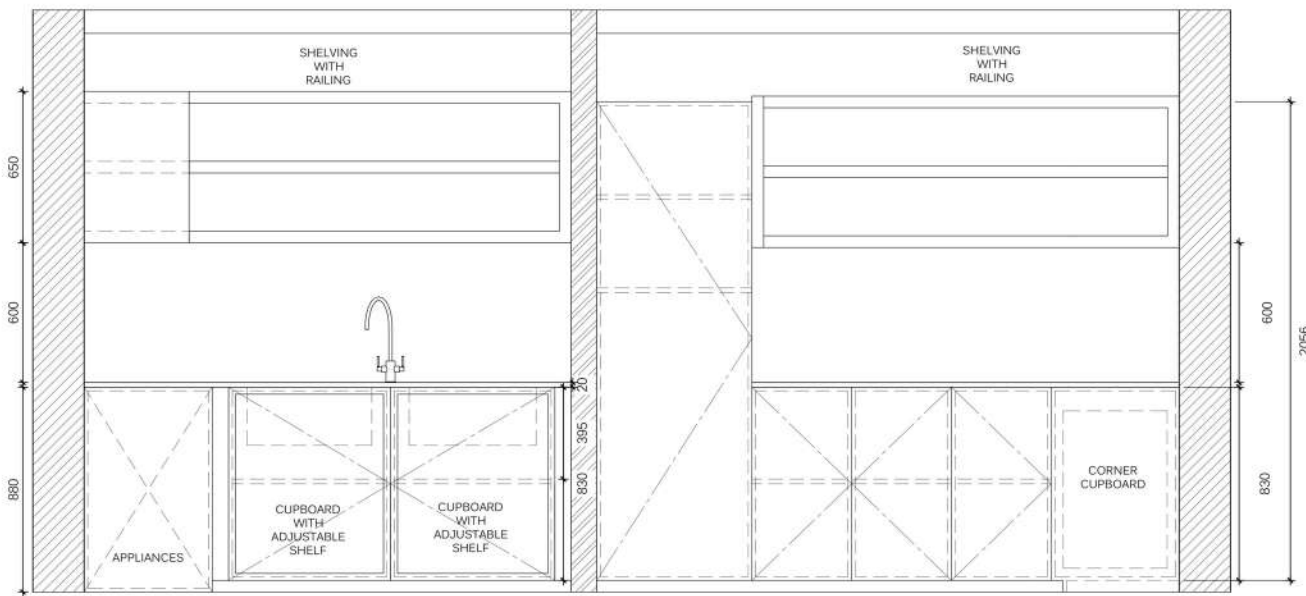

KITCHEN B ELEVATION NTS

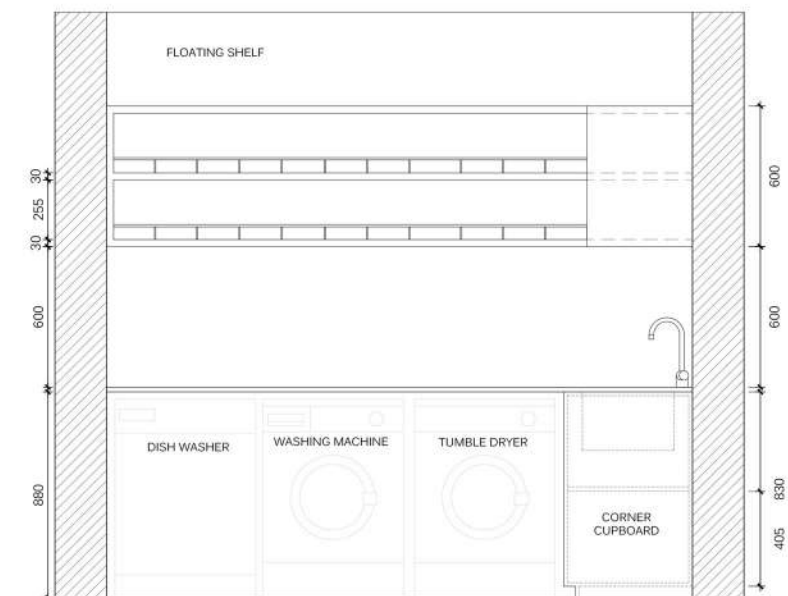

KITCHEN C ELEVATION NTS

KSA | KITCHEN

KSA | KITCHEN ELEVATIONS

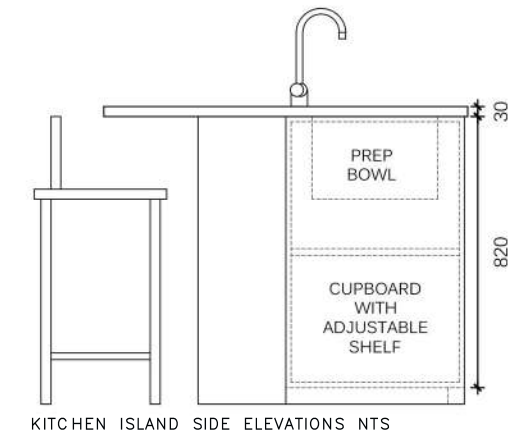
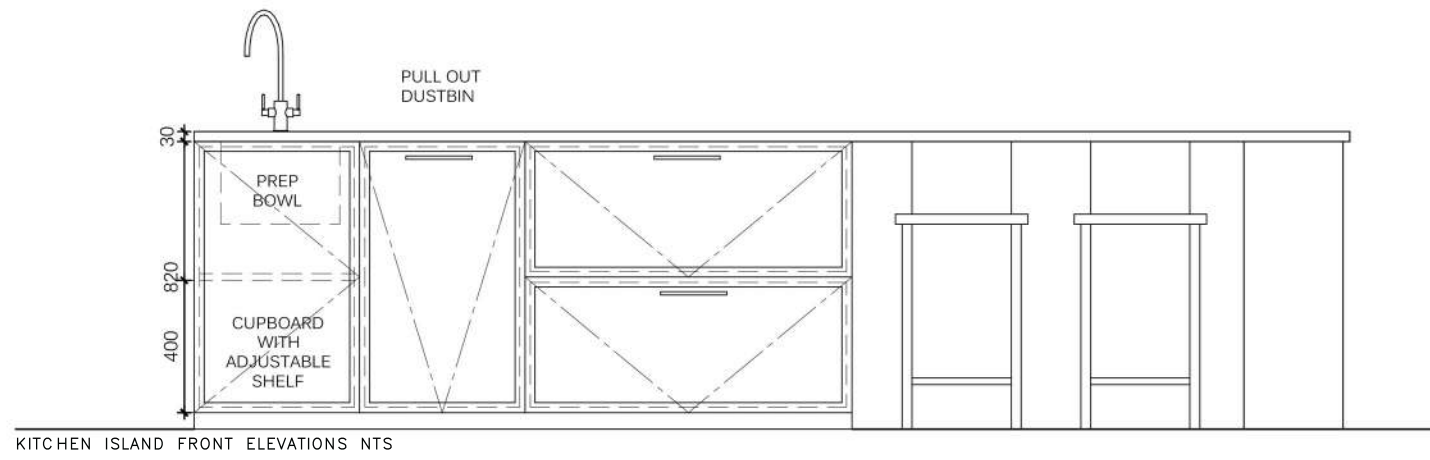
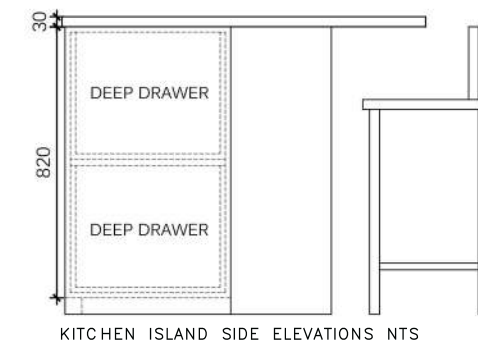
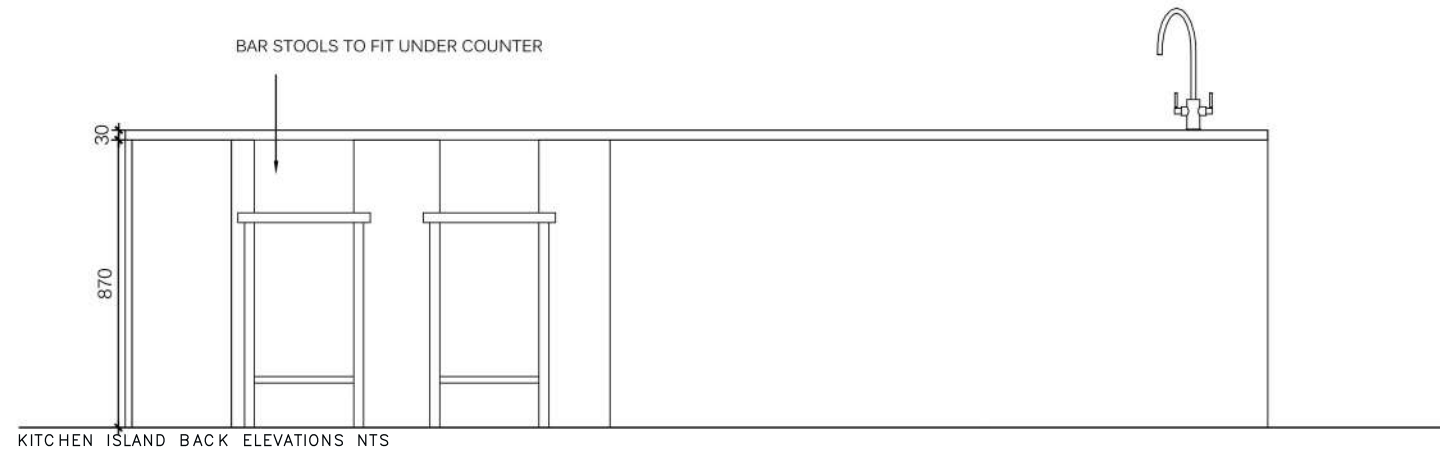

03.

P G B I S O N

1 6 X O N E I G H T | T H E B I G B R I E F

HOUSING IS BEING PROVIDED FOR THE LOWER-LEVEL INCOME COMMUNITY. I WILL BE USING USING SUSTAINABLE MATERIAL FOR THE CONSTRUCTION LIKE THE USE OF RAMMED EARTH FOR THE CONSTRUCTION OF THE BUILDING. ALL SPACES ARE OPEN PLANNED WITH THE NECESSARY AMENITIES. THE AESTHETIC I AM GOING FOR IS MINIMALISTIC AND INSPIRED BY THE MELLOW LOOK OF GREECE, THIS COMPLIMENTS THE TO LOW COST LIVING.

I WANTED TO CREATE A COMMUNAL SPACE FOR THE COMMUNITY. BY MAKING IT FEEL COMMUNAL I INCLUDED A CONVENIENCE STORE AND A LAUNDROMAT. THIS ALSO MEANS THE COMMUNITY SAVES TRANSPORT MONEY AND RISKING THEIR SAFETY. PG BISON WILL BE ASSISTING TO BRING THIS MODULA LIVING TOGETHER.



OUTSIDE VIEW OF BUILDING



COMMUNAL SEATING & EATING AREA



COMMUNAL OUTSIDE SEATING



BATHROOM 1



KITCHEN & LIVING ROOM 2



BATHROOM 2



KITCHEN 2



LAUNDROMAT



ENTRANCE TO LAUNDROMAT



CONVENIENCE STORE



CONVENIENCE STORE

P G B I S O N | U N I T F L O O R P L A N

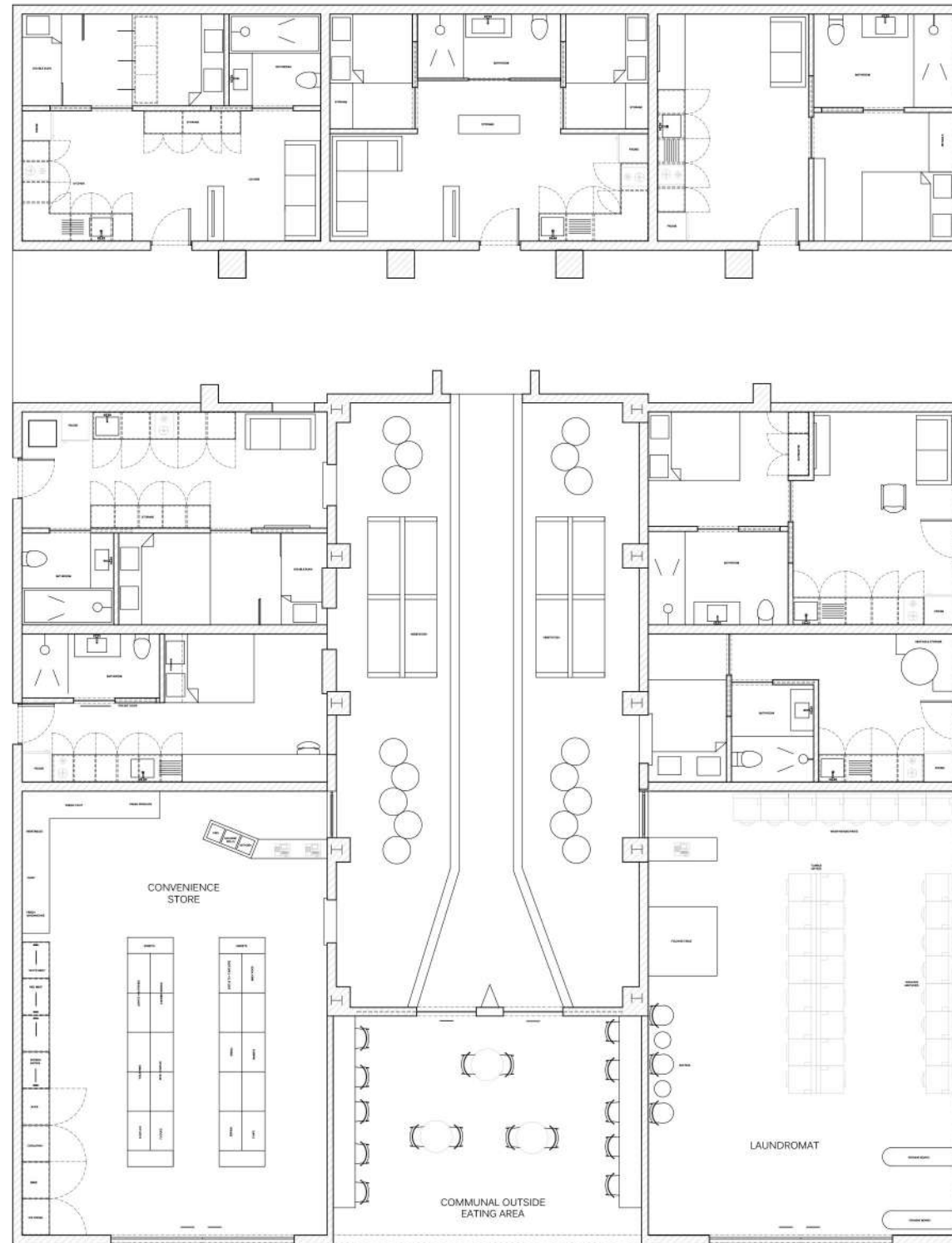

FLOORPLAN NTS



P G B I S O N -
E S S P R E S O



P G B I S O N -
A Z Z A N O



P G B I S O N -
P E T R O L B L U E

04. TREE HOUSE

WHITE BOX

A LINEAR DESIGN AMONGST AN OAK FOREST IN HARADS, SWEDEN. WHERE THE CLIENTS WILL ENJOY A COZY GET-AWAY FROM THE CITY LIFE. THE BLACK "BOX" SHAPE IS IN CONTRAST WITH ITS SOFT SNOWY LANDSCAPE, AND THE HORIZONTAL DESIGN WITH THE VERTICAL TREE LINES. WHILE THE INTERIOR COLOUR PALETTE REFELCTS THE MOOD OF THE EXTERIOR. THIS MODERN DESIGN OFFERS AND OFF THE GRID EXPEREINCE, ALLOWING ONE TO GLIDE THROUGH THE TREES, MOVING FROM ONE SPACE TO ANOTHER.



EXTERIOR VIEW OF THE WHITE BOX



T R E E H O U S E | W H I T E B O X



BEDROOM VIEW



BATHROOM & KITCHEN VIEW



BATHROOM & KITCHEN VIEW

WHITE BOX FLOORPLAN & ELEVATION

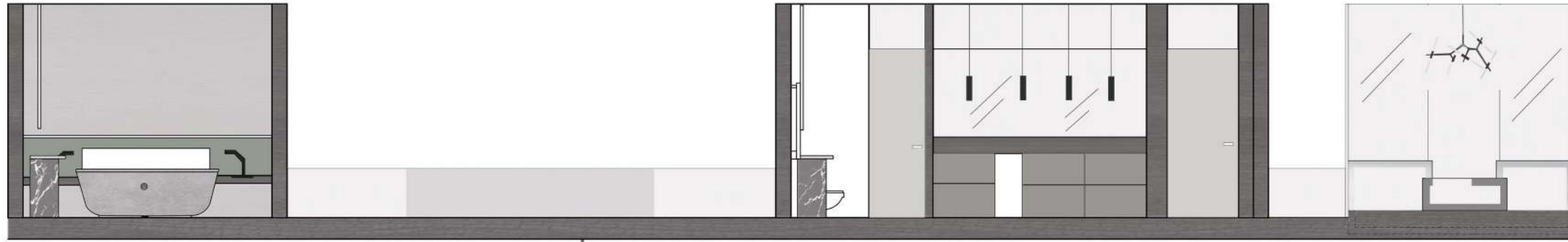

ELEVATION NTS

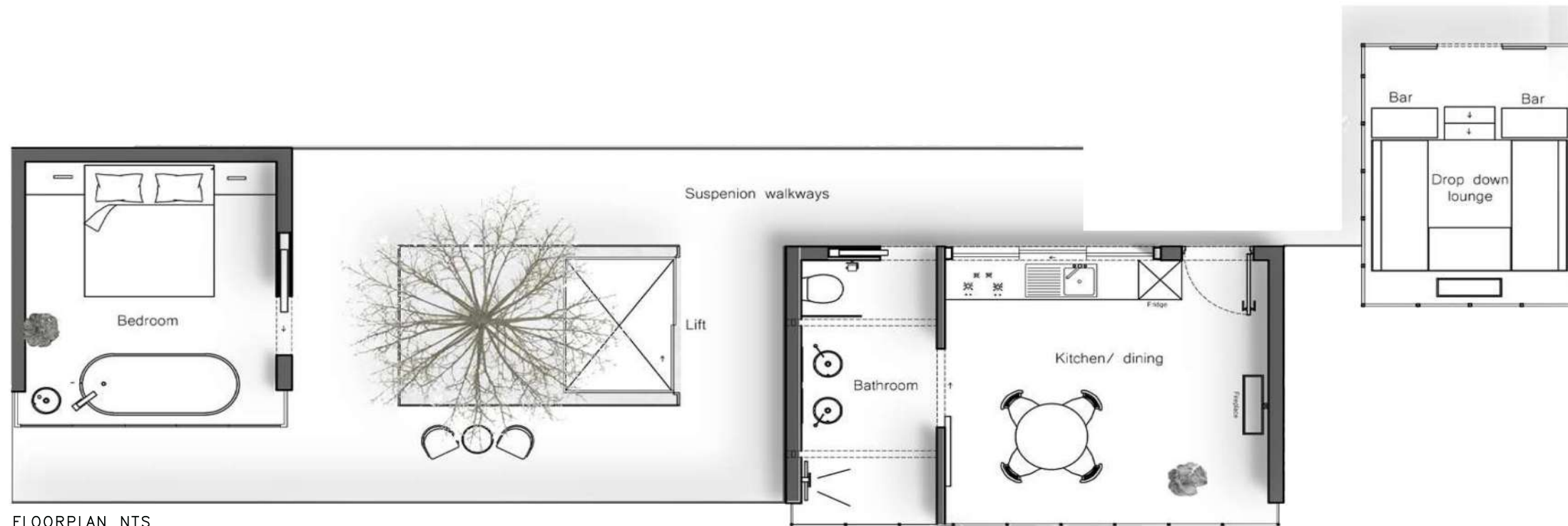

FLOORPLAN NTS

05.
D O C K H A U S
H O T E L L O B B Y , G R O U P P R O J E C T

DOCK HAUS IS A FIRST YEAR GROUP PROJECT. THE HOTEL LOBBY AREA IS SPECIFICALLY DESIGNED FOR ALL THE ARTISTS TO APPRECIATE THE UNIQUE FURNITURE SHAPES AND COLORS. AROUND EVERY CORNER THERE IS ART TO SEE, THE FURNITURE, THE SELECTED DECOR.



FIRST VIEW OF RECEPTION



RIGHT SIDE VIEW



CUSTOM BUILT RECEPTION DESK



SCENIC VIEW



LEFT SIDE VIEW



FURNITURE CLUSTERS

LOBBY FLOORPLAN

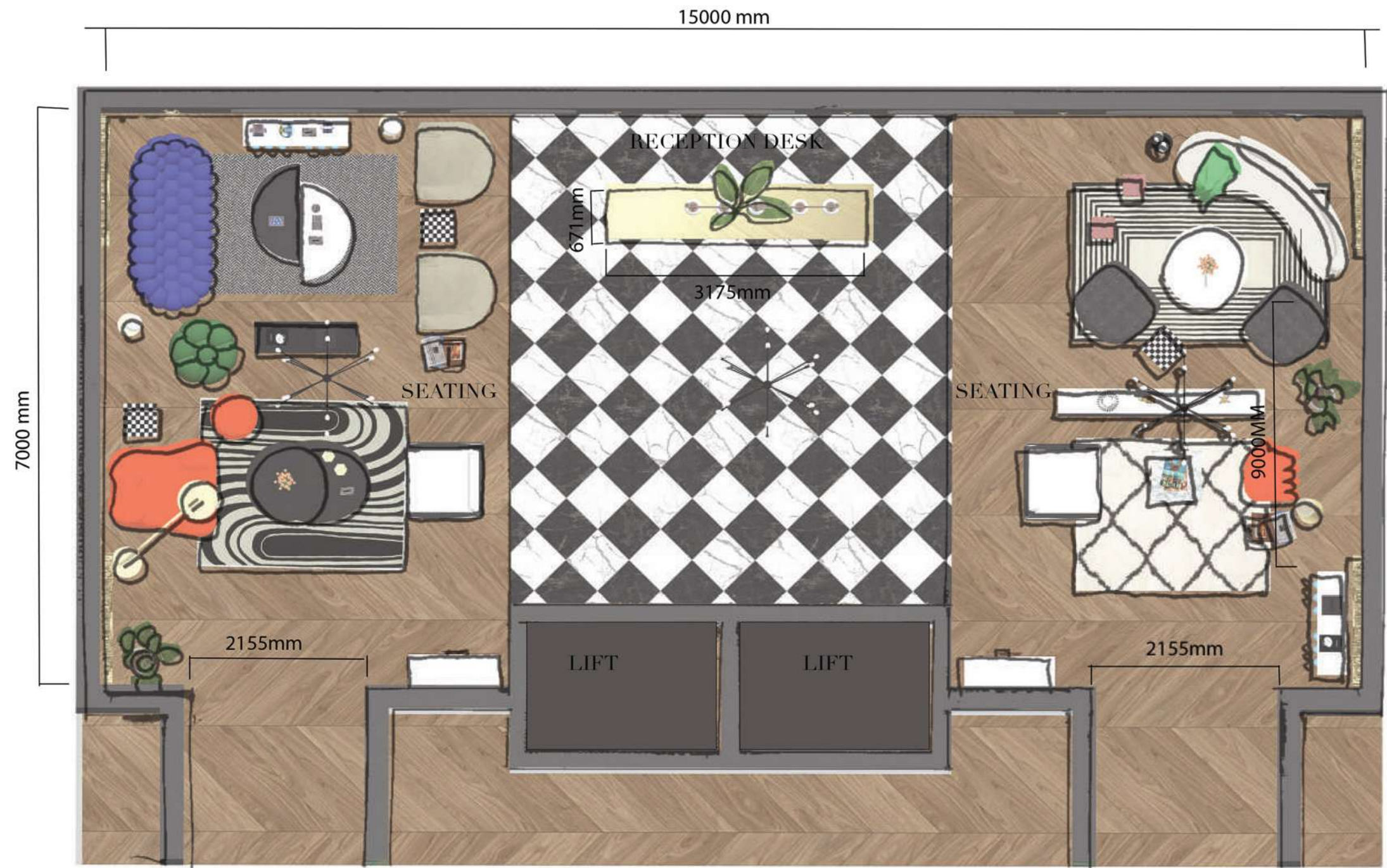

FLOORPLAN NTS

2D MATERIAL BOARD

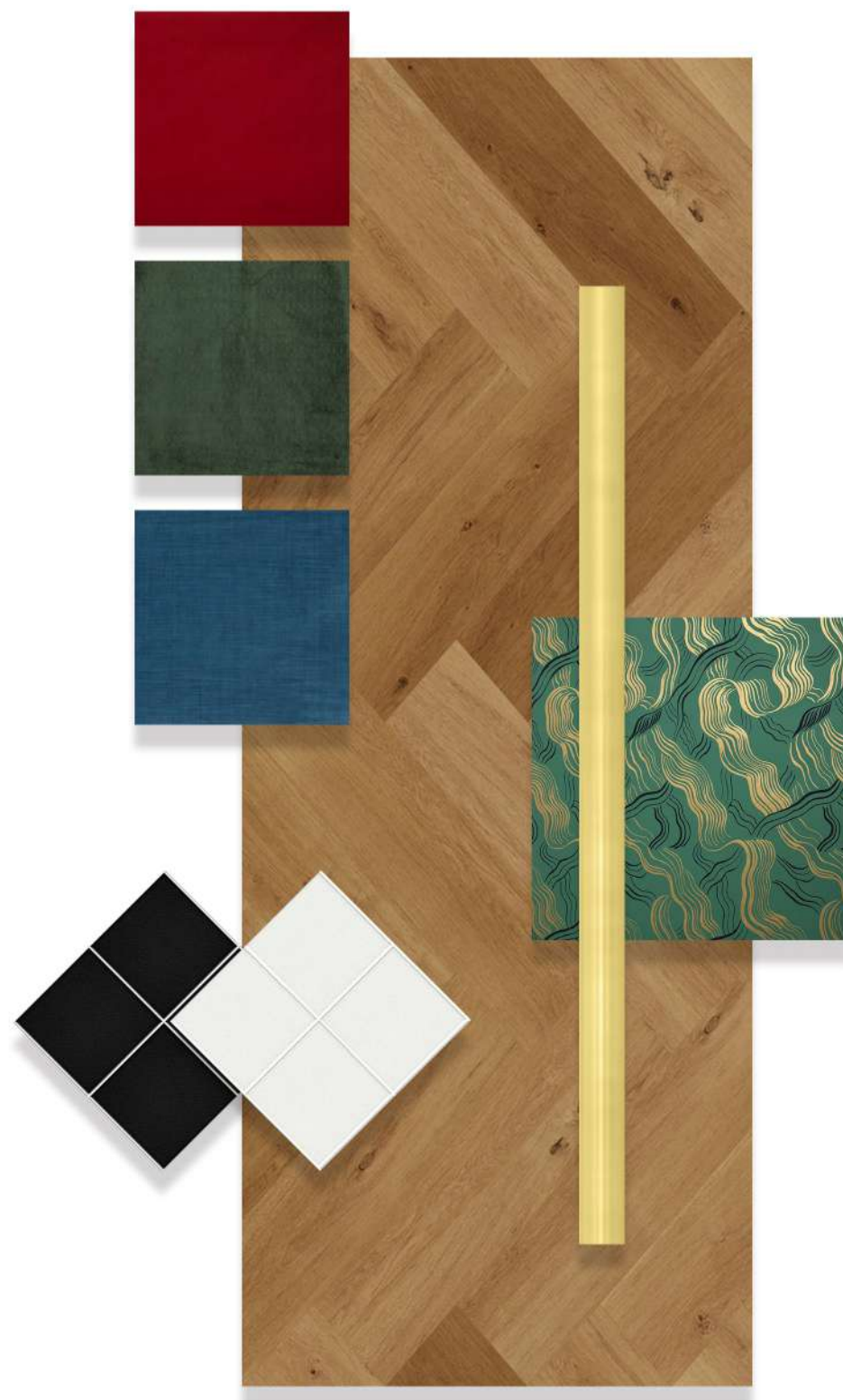

06. RESIDENTIAL
DESIGN

A MIDDLE AGED COUPLE LIVING IN A MODERN YET CLASSICAL HOME. CLASSY FOR ENTERTAINMENT AND COZY FOR RELAXATION.

R E S I D E N T I A L D E S I G N | B A T H R O O M

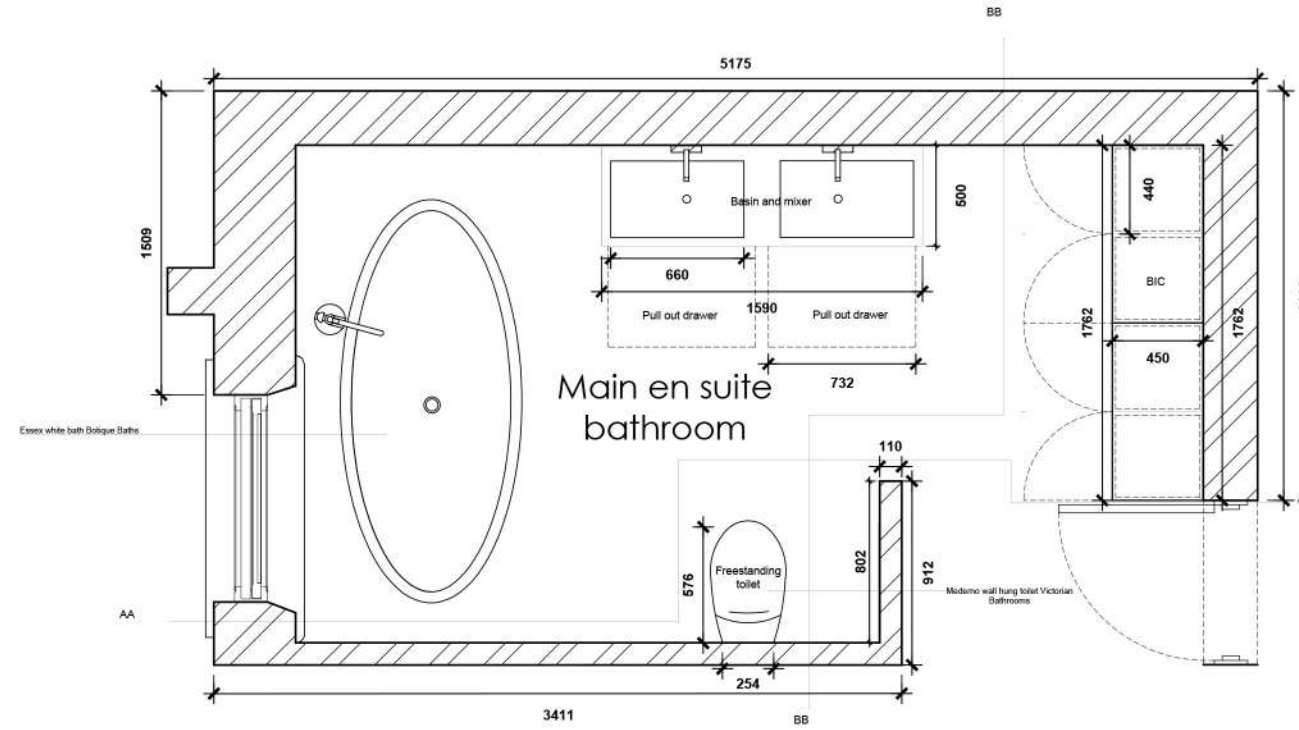

BATHROOM FLOORPLAN NTS

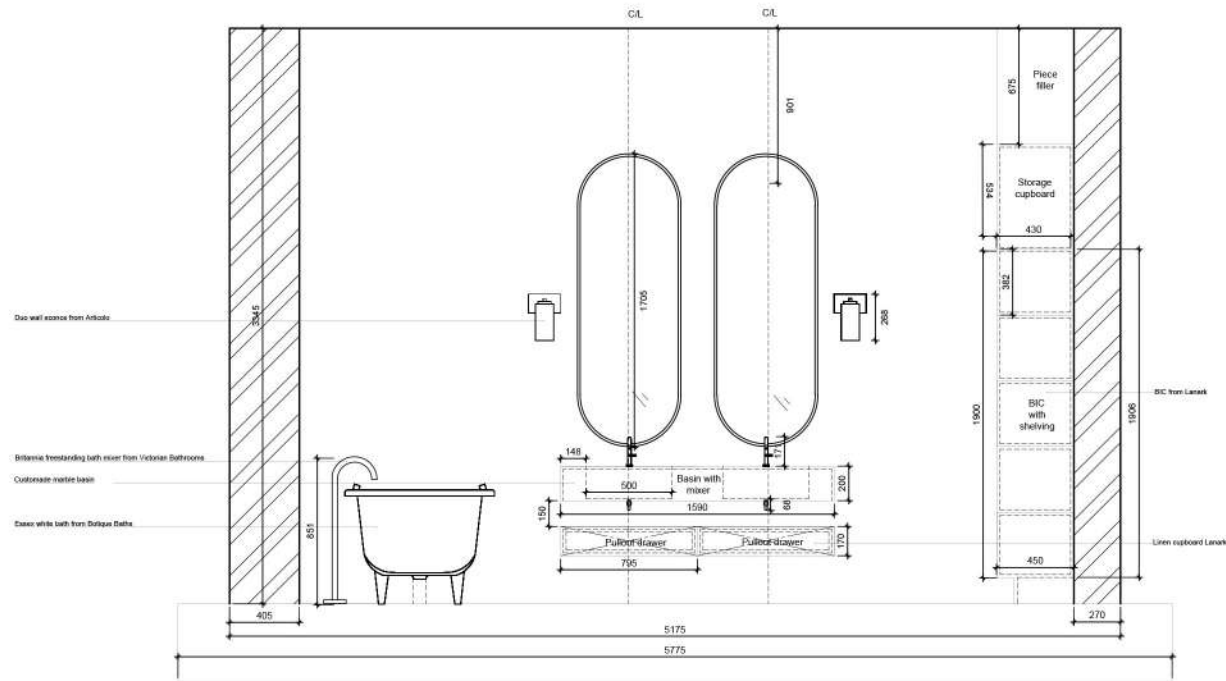

BATHROOM AA ELEVATION NTS

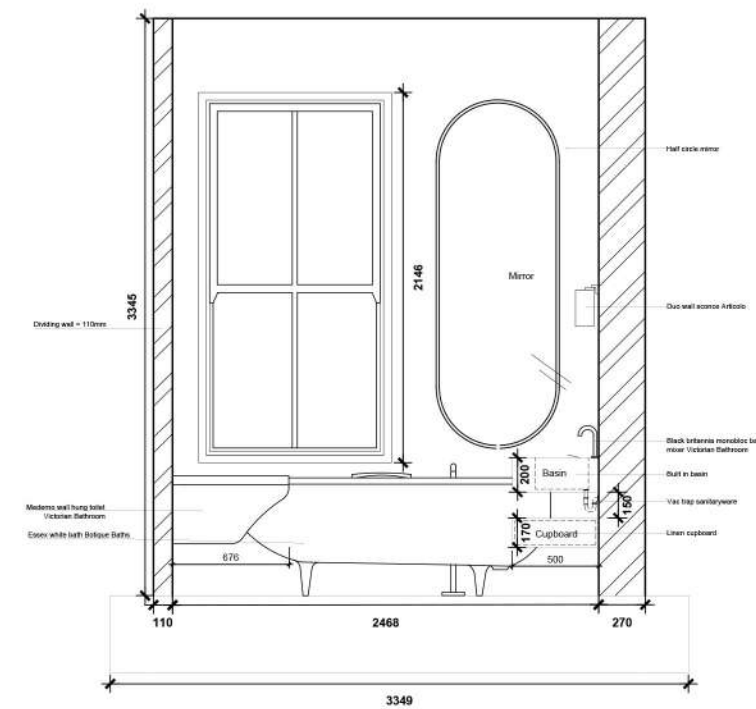

BATHROOM BB ELEVATION NTS

07.
W O R K I N G D R A W I N G
P A C K A G E

IN THIS WORKING DRAWING PACKAGE T CONSISTS OF A DEMOLITION BUILDING , NEW BUILDING ,
FLOOR FINISH , DATA & ELEC , LIGHTING AND WINDOW & DOOR LAYOUTS.

NEW BUILD FLOORPLAN

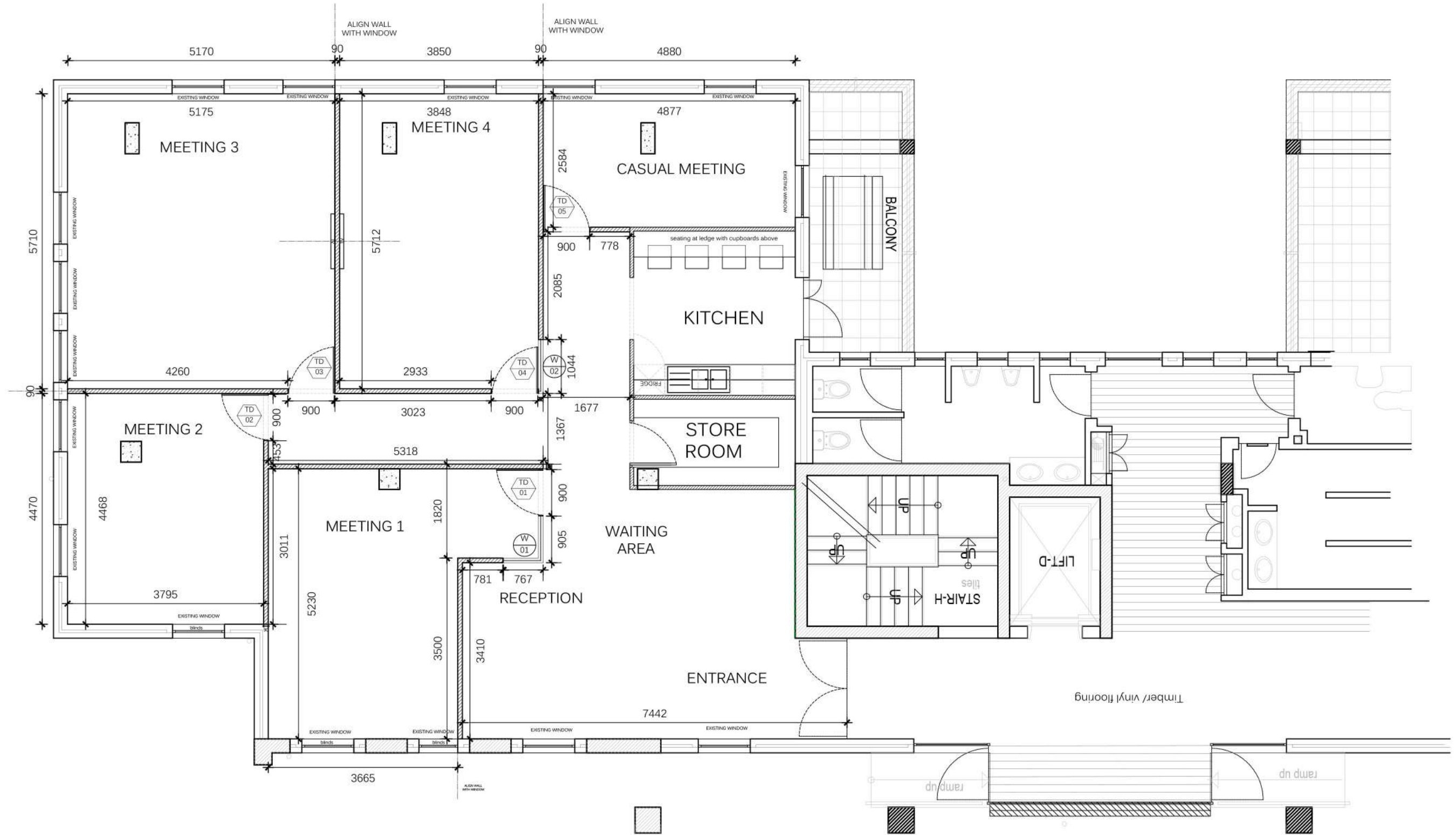

FLOORPLAN NTS

FLOOR FINISH FLOORPLAN

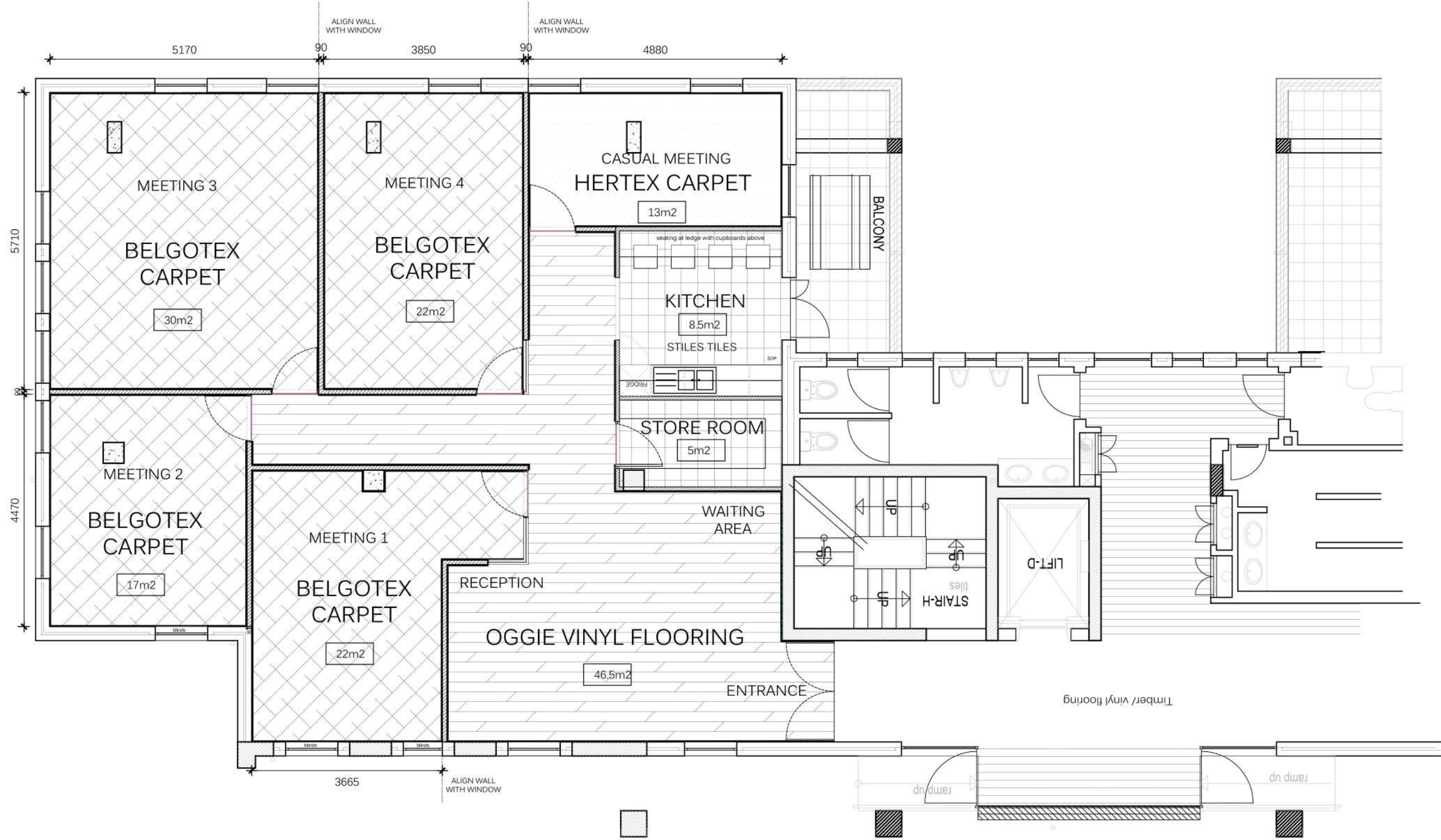

DATA & ELEC FLOORPLAN

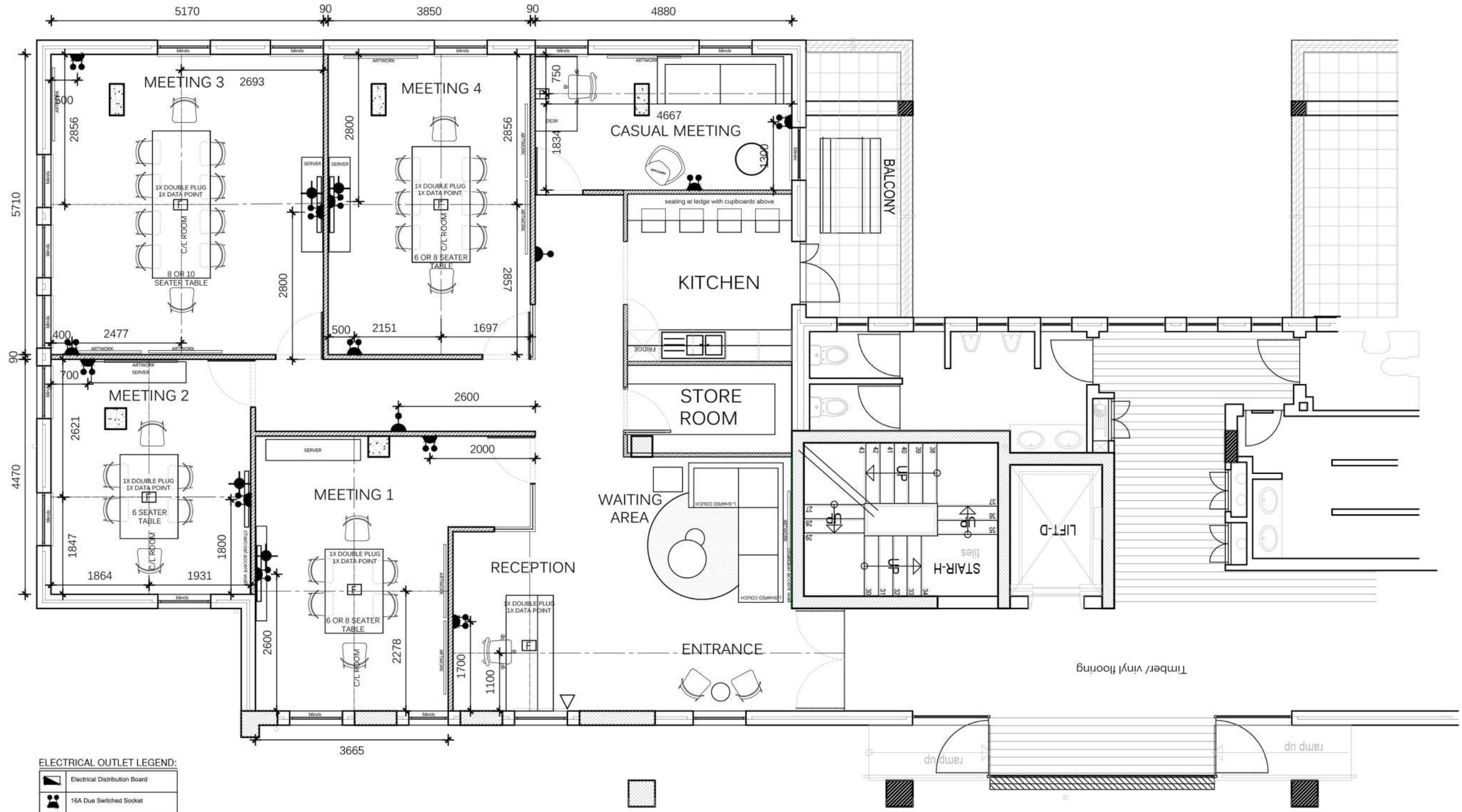

ELECTRICAL OUTLET LEGEND:

	Electrical Distribution Board
	16A Double Switched Socket
	16A Single Switched Socket
	Bell at front entrance with motion sensor
	TV antenna point
	100mm x 100mm Floor box as per spec
	Telephone Point
	Data Point

FLOORPLAN NTS

DOOR & WINDOW ELEVATION

PROJECT TIMBER DOOR SCHEDULE

DOOR TYPE	DOOR NUMBERS	TOTAL
A	BASEMENT LEVEL N/A	0
	GROUND FLOOR TD01, TD02, TD03, TD04, TD05	5
	FIRST FLOOR N/A	0
	Description DOOR VANISHED WITH DOOR FRAME PAINTED WHITE	
Size	AS DIMENSIONED - CHECK ON SITE	
Glazing	N/A	
Ironmongery	BUILDER TO ALLOW PC OF 150MM FOR DOUBLE SIDED HANDLE SET AND KEY HOLE COMBINATION. HINGES AS PER BUILDER SPEC.	
Notes and special conditions	HANDLES MOUNTED AS PER MANUFACTURER'S OPTIMIZE SIZE TO BE CHECKED ON SITE BEFORE INSTALLATION ADOTE TO BE TO BE ON BUTTERFLY HANDS	

ALUMINUM WINDOW SCHEDULE

WINDOW TYPE	WINDOW NUMBERS	TOTAL
B	BASEMENT LEVEL N/A	0
	GROUND FLOOR GL 01, GL 02	2
	FIRST FLOOR N/A	0
	Description AS DIMENSIONED - CHECK ON SITE	
Size	AS DIMENSIONED - CHECK ON SITE	
Glazing	4mm CLEAR FLOAT GLASS AS PER NBR ALL FRAMES TO BE POWER COATED BLACK	
Ironmongery	10MM BLACK POWDER COATED ALUMINUM FRAME AS PER BUILDER SPEC.	
Notes and special conditions		